



UNIVERSIDAD
DE SANTIAGO
DE CHILE

Universidad de Santiago de Chile
Facultad de Ingeniería
Departamento de Ingeniería
Mecánica



“Ayudantía N°3”

Ayudantes:
Andreas Krumpoeck Aigner
Juan Santiago Olmedo



Figura 1:

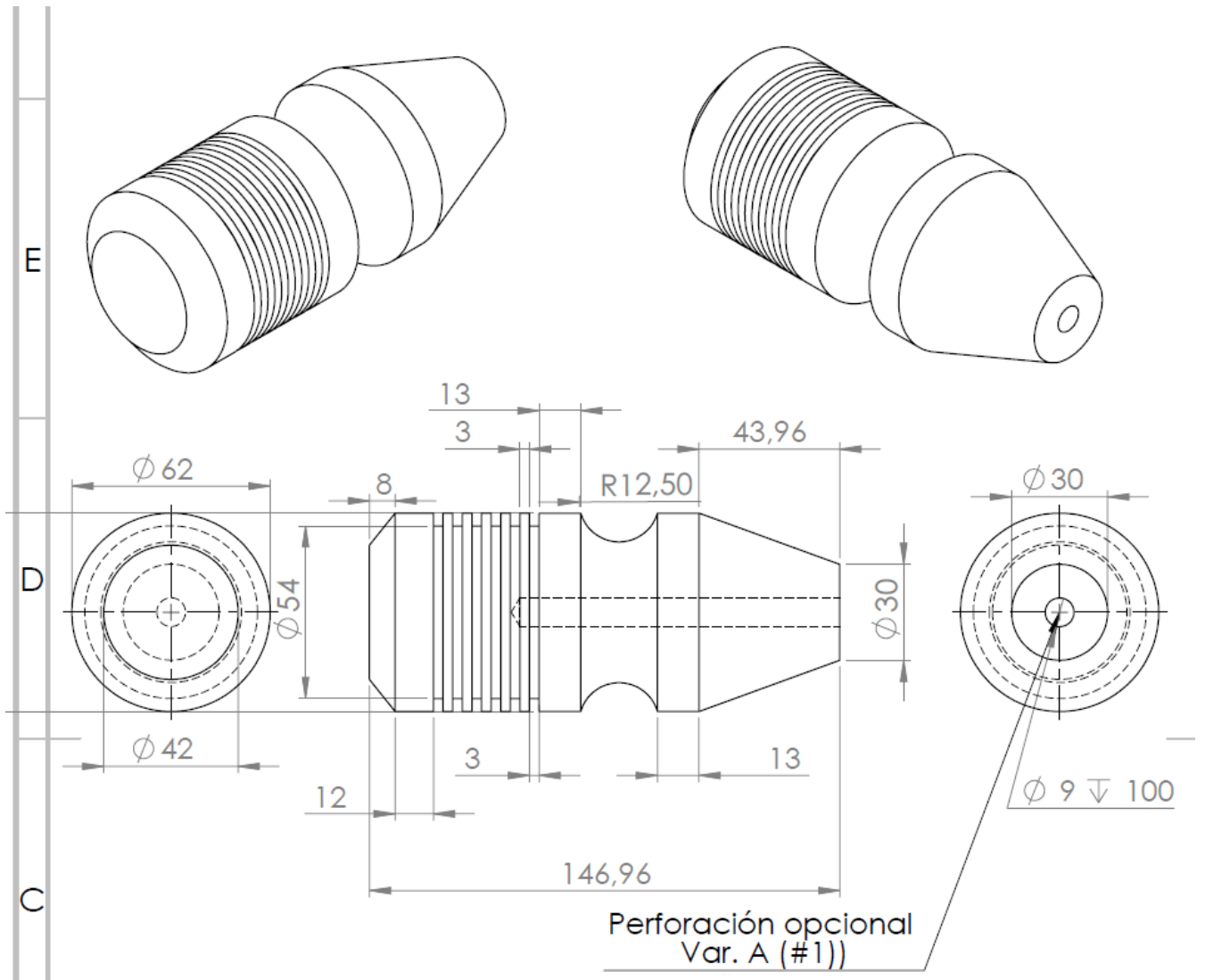

Solución figura 1:

O7001;
S200 M03;
F160;
G00 X100. Z0.;
(TALAD);
G28 U0. W0.;
T0202;
G01 X0.;
Z0.;
M98 P7002 L9;
G90;
G00 Z100.;
X100. Z0.;
(DESBASTE);
G28 U0. W0.;
T0101;
G01 X62. Z0.;
#100=19.99;
G01 X62. Z[-16./TAN[#100]];
G00 X62. Z0.;
G01 X58.;
Z[-14./TAN[#100]];
G00 X62. Z0.;
G01 X54.;
Z[-12./TAN[#100]];
G00 X62. Z0.;
G01 X50.;
Z[-10./TAN[#100]];
G00 X62. Z0.;
G01 X46.;
Z[-8./TAN[#100]];
G00 X62. Z0.;
G01 X42.;
Z[-6./TAN[#100]];
G00 X62. Z0.;
G01 X38.;
Z[-4./TAN[#100]];
G00 X62. Z0.;
G01 X34.;
Z[-2/TAN[#100]];
G00 X62. Z0.;
G01 X30 Z[0./TAN[#100]];
G00 X62. Z0.;
(CENTRAL);
G00 X100. Z0.;
G28 U0. W0.;

T0303;
G01 X30. Z0.;
X62. Z-43.96;
Z-56.96;
G02 Z-80.96 R12.5;
G01 Z-139.96;
Z-146.96 X42.;
G00 X100.
Z0.
(RANURADO Y TRONZADO);
G28 U0. W0.;
T0505;
G00 X100. Z0.;
Z-93.96;
X64.;
G01 X54.;
G00 X64.;
G00 Z-99.96;
G01 X54.;
G00 X64.;
G00 Z-105.96;
G01 X54.;
G00 X64.;
G00 Z-111.96;
G01 X54.;
G00 X64.;
G00 Z-117.96;
G01 X54.;
G00 X64.;
G00 Z-123.96;
G01 X54.;
G00 X64.;
G00 X70. Z-146.96;
G01 X-1.;
G00 X100.;
Z100.;
M05;
M30;

O7002;
G91;
G01 W-20.;
G01 W10.;
G90;
M99;