

Ayudantía N°1

Ayudantes:

Andreas Krumpoeck

Juan Santiago

Figura N°1:



Figura N°2:



Solución Figura N°1:

O2000;

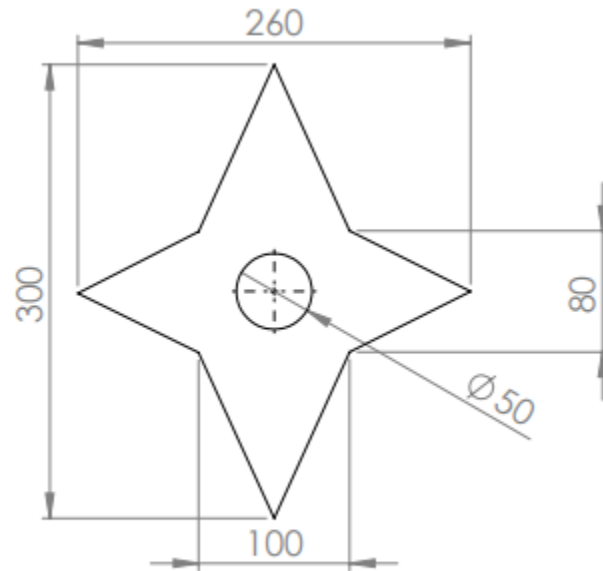
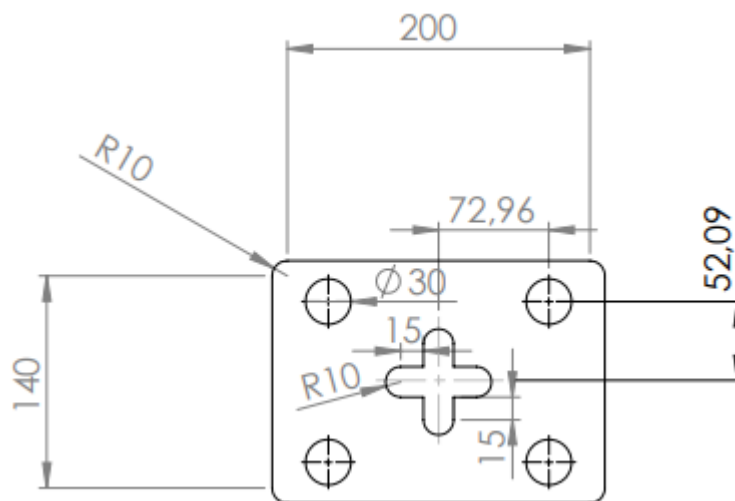
G00 X50. Y200. Z10.;

G01 X0. Y150. Z2.;

Z0.;

X-50. Y40.;

X-130. Y0.;

X-50. Y-40.;

X0. Y-150.;

X50. Y-40.;

X130. Y0.;

X50. Y40.;

X0. Y150.;

Z10.;

G00 X0. Y0.;

G01;

X25. Y0.;

Z0.

G03 I-25.;

M30;

Solución Figura N°2:

O2001;	G00 Z10.;
G00 X250. Y200. Z10.;	G00 X87.96 Y-52.09;
(CONTORNO)	G01 Z0.;
G01 X100. Y80. Z0.;	G03 I-15.;
X-100.;	G00 Z10.;
G03 X-110. Y70. R10.;	(CRUZ)
G01 Y-70.;	G00 X10. Y10.;
G03 X-100. Y-80. R10.;	G01 Z0.;
G01 X100.;	Y25.;
G03 X110. Y-70. R10.;	G03 X-10. I-10.;
G01 Y70.;	G01 Y10.;
G03 X100. Y80. R10.;	X-25.;
G01 Z10.;	G03 Y-10. J-10.;
(CIRCUNFERENCICAS)	G01 X-10;
G00 X87.96 Y52.09;	Y-25.;
G01 Z0.;	G03 Y-25. X10. R10.;
G03 I-15.;	G01 Y-10.;
G00 Z10.;	X25.;
G00 X-87.96 Y52.09;	G03 Y10. R10.;
G01 Z0.;	G01 X10. Y10.;
G02 I15.;	G00 Z10.;
G00 Z10.;	G00 X250. Y200. Z10.;
G00 X-87.96 Y-52.09;	M30;
G01 Z0.;	
G02 I15.;	